

Models

Unloader/Regulator

22971C/22971CR/22973C/22973CR/ 22974/22974R

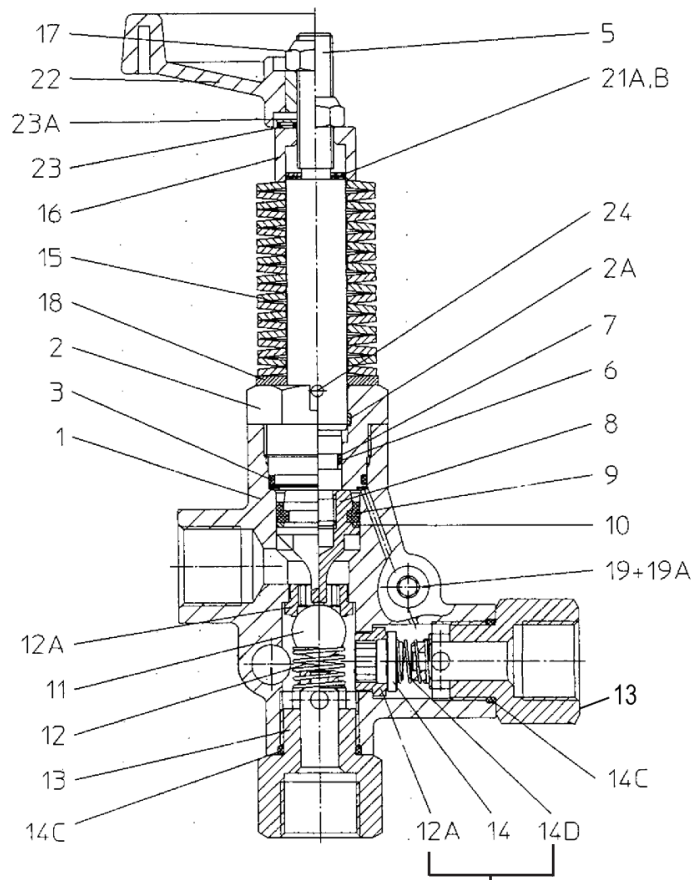

22971C/22973C/22974 = Unloader
22971CR/22973CR/22974R = Regulator

When ordering handwheel versions add "H" to model number

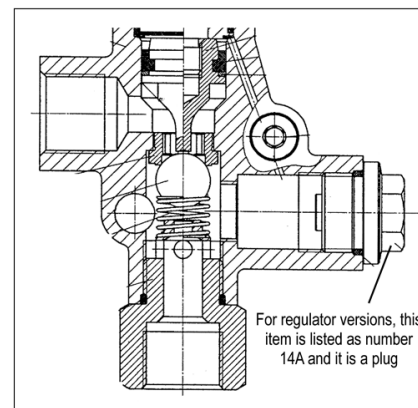

Not present in 22971CR and 22973CR

Item	Part #	Description	Qty.	Item	Part #	Description	Qty.
1	12232	Valve Body	1	14C	07035	O-Ring	2
2	12240	Guide Plug	1	14D	06017-0100	Spring, Outlet Valve (unloader versions)	1
2A	12241	Guide Ring	1	15	12218	Spring, Yellow (22971C)	21
3	12057	O-Ring	1	15	12220	Spring, Orange (22973C)	19
5	12242	Piston Rod	1	15	04284	Spring, Silver (22974)	23
6	12204	O-Ring, Valve Stem	1	16	12245	Spacer Sleeve	1
7	12205	Backup Ring, Valve Stem	1	17	12246	Self-Locking Hexagon Nut	1
8	12206	Piston	1	18	12223	Washer, Spring	1
9	05005	Cup, 28mm	1	19	06685	Plug	4
10	05015	Backup ring, 28mm	1	19A	12017	O-Ring, Plug	4
11	12207	Ball	1	21A	06821	Spacer Disc, 0.5 mm	1
12	12216	Valve Spring	1	21B	06822	Spacer Disc, 1.0 mm	3
12A	12208	Seat, Inlet	1	22	06774	Spoked Handwheel ("H" versions)	1
13	12243	Valve Plug (unloader versions)	2	23	06775	Axial Needle Bearing ("H" versions)	1
13	12243	Valve Plug (regulator versions)	1	23A	06776	Disc ("H" versions)	1
14	12244	Valve Plate (unloader versions)	1	24	12247	Serrated Pin	1
14A	06820	Discharge Plug (only regulator versions)	1				

Repair Kit: **Part Number** 09461 **Parts Included:** 2A, 3, 6, 7, 9, 10, 11, 12, 12A, 14, 14C, 14D, 19A **NOTE:** This kit includes both o-ring part numbers 12057 and 07332 (item #3). Discard unused o-ring.

Part Substitutions: Unloaders manufactured prior to May, 1985 use Valve Body #12201
 Unloaders manufactured between May, 1985 and July 1989 use Valve Body #12230
 Unloaders manufactured prior to July, 1989 use Valve Cap #12202
 Unloaders manufactured prior to July, 1989 use O-Ring #07332
 Unloaders manufactured prior to May, 1985 use Valve Retainer #12211

SPECIFICATIONS:

Pressure Range:		Minimum Flow:	2.1 GPM (8 LPM)
(22971C/22971CR):	580-1740 PSI (40-120 Bar)	Maximum Temp.:	158 °F (70 °F)
(22973C/22973CR):	580-4060 PSI (40-280 Bar)	Inlet Port:	3/4" FNPT
(22974/22974R):	362-580 PSI (25-40 Bar)	Outlet Port:	3/4" FNPT
Maximum Flow:	35.7 GPM (135 LPM)	Bypass:	3/4" BSP
	(22971C/22971CR/22974/2297R)		
	26.4 GPM (99 LPM)		
	(22973C/22973CR)		

INSTALLATION OF 22971C(R), 22973C(R), AND 22974(R) UNLOADERS/REGULATORS

- 1) The unloader is to be positioned on the discharge side of the pumping unit.
- 2) The bottom port (inlet) receives the pump discharge.
- 3) The side port (outlet) is the pressure outlet. Make sure all side ports are tightened securely.
- 4) The backside port (bypass) redirects the pumped media when the pressure outlet is closed.
- 5) The proper sized bypass line can be directed to a holding tank, to atmosphere, or back to the pump inlet.

NOTE: Bypass lines returning to the pump inlet should be equipped with a thermal relief valve to prevent excessive heat buildup in the bypass line that can damage the pumping system during periods of prolonged bypass.

- 6) If a pulsation dampener (accumulator) is used in your pumping system, the pulsation dampener (accumulator) must be positioned on the downstream side of the unloader. **REMEMBER:** IMPROPER PLACEMENT OF THE PULSATION DAMPENER (ACCUMULATOR) CAN AFFECT THE UNLOAD CAPACITY OF THE UNLOADER AND CAN LEAD TO SEVERE SYSTEM DAMAGE AND POSSIBLE BODILY INJURY.

CAUTION: A properly sized pressure gauge must be used when attempting to adjust the unloader to its pressure setting. Position the gauge between the pump and the unloader.

- 7) Select the proper spring assembly for your unloader. All spring ratings are based on the maximum operating pressure of the unloaders.

Silver Springs: 22974/22974R
 Yellow Springs: 22971C/22971CR
 Orange Springs 22973C/22973CR

NOTE: Cracking pressures at which the unloader is activated can rise 300-400 PSI over the rated operating pressures depending on your system.

- 8) Always adjust the unloader springs to the system pressure with the system open. Before adjusting, be sure that the spray nozzle orifice is properly sized for the volume and pressure you desire and then fine tune the unloader.

CAUTION: NEVER USE THE UNLOADER TO COMPENSATE FOR A WORN NOZZLE AS YOU RISK BOTTOMING-OUT THE UNLOADER, WHICH CAN CAUSE THE UNLOADER TO MALFUNCTION AND LEAD TO SEVERE SYSTEM DAMAGE AND POSSIBLE BODILY INJURY.

- 9) Giant Industries, Inc. strongly recommends the use of a pop-off valve positioned downstream of the unloader as a safety backup in case of unloader malfunction.



Giant Industries, Inc.
 900 N. Westwood Ave.
 Toledo, Ohio 43607
 PHONE (419) 531-4600
 FAX (419) 531-6836
 www.giantpumps.com